



# Cambridge IGCSE™

CANDIDATE  
NAME

CENTRE  
NUMBER

--	--	--	--	--

CANDIDATE  
NUMBER

--	--	--	--

## CHEMISTRY

0620/43

Paper 4 Theory (Extended)

October/November 2022

1 hour 15 minutes

You must answer on the question paper.

No additional materials are needed.

### INSTRUCTIONS

- Answer **all** questions.
- Use a black or dark blue pen. You may use an HB pencil for any diagrams or graphs.
- Write your name, centre number and candidate number in the boxes at the top of the page.
- Write your answer to each question in the space provided.
- Do **not** use an erasable pen or correction fluid.
- Do **not** write on any bar codes.
- You may use a calculator.
- You should show all your working and use appropriate units.

### INFORMATION

- The total mark for this paper is 80.
- The number of marks for each question or part question is shown in brackets [ ].
- The Periodic Table is printed in the question paper.

This document has **16** pages. Any blank pages are indicated.



1 Atoms and ions are made from small particles called electrons, neutrons and protons.

(a) Complete the table.

particle	relative charge	relative mass
electron	-1	$\frac{1}{1840}$
neutron		
proton		

[2]

(b) Information about atoms and ions, **A**, **B** and **C**, is shown in the table.

Complete the table.

atom or ion	number of electrons	number of neutrons	number of protons	symbol
<b>A</b>	18		20	${}_{20}^{42}\text{Ca}^{2+}$
<b>B</b>		18		${}_{17}^{35}\text{Cl}$
<b>C</b>	18	16	16	

[6]

[Total: 8]

- 2 The table shows the melting points, boiling points and electrical conductivities of six substances, **D**, **E**, **F**, **G**, **H** and **I**.

substance	melting point /°C	boiling point /°C	conducts electricity when solid	conducts electricity when liquid
<b>D</b>	1083	2567	yes	yes
<b>E</b>	-117	79	no	no
<b>F</b>	3550	4827	no	no
<b>G</b>	119	445	no	no
<b>H</b>	-210	-196	no	no
<b>I</b>	801	1413	no	yes

- (a) Identify the substance, **D**, **E**, **F**, **G**, **H** or **I**, which is:

(i) a liquid at 25°C ..... [1]

(ii) a gas at 25°C ..... [1]

(iii) a solid consisting of simple molecules at 25°C. .... [1]

- (b) Identify the substance, **D**, **E**, **F**, **G**, **H** or **I**, which is a metal. Give a reason for your choice.

substance .....

reason ..... [2]

- (c) Identify the substance, **D**, **E**, **F**, **G**, **H** or **I**, which has a macromolecular structure. Give **two** reasons for your choice.

substance .....

reason 1 .....

reason 2 ..... [3]

- (d) Identify the substance, **D**, **E**, **F**, **G**, **H** or **I**, which is an ionic solid. Give a reason for your choice.

substance .....

reason .....

..... [2]

[Total: 10]

3 Aluminium is extracted from its ore by electrolysis.

(a) Name the ore of aluminium which consists mainly of aluminium oxide.

..... [1]

(b) State what is meant by the term *electrolysis*.

.....  
 ..... [2]

(c) Electrolysis is carried out on aluminium oxide dissolved in molten cryolite.

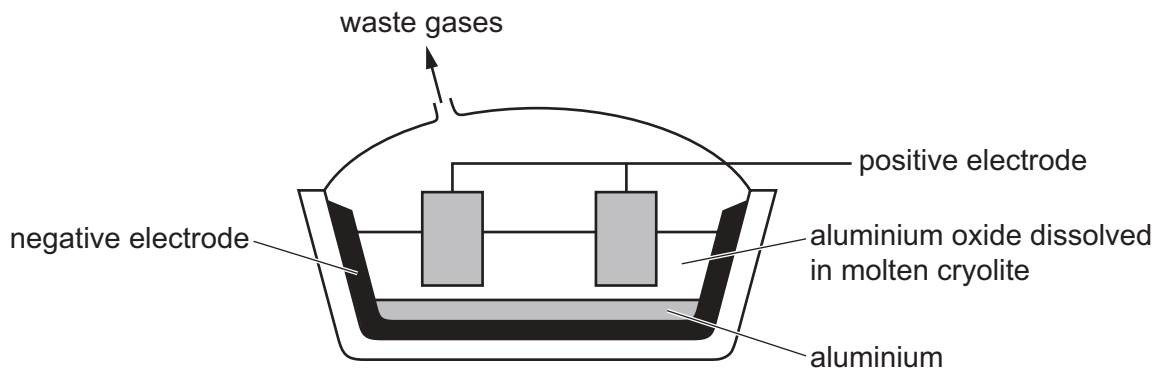

(i) Give **two** reasons why the electrolysis is carried out on aluminium oxide dissolved in molten cryolite instead of electrolysis molten aluminium oxide only.

1 .....

2 .....

[2]

(ii) Write the ionic half-equation for the reaction occurring at the negative electrode.

..... [2]

(iii) The positive electrodes are made of carbon.

Explain why the positive carbon electrodes are replaced regularly.

.....

..... [2]

(d) Aluminium is more reactive than copper.

When aluminium is added to aqueous copper(II) sulfate, no immediate reaction is seen.

Explain why.

..... [1]

(e) Aluminium reacts with oxygen to form an amphoteric oxide.

(i) State what is meant by the term *amphoteric*.

.....  
 ..... [1]

(ii) The reaction between aluminium oxide and aqueous sodium hydroxide forms a salt containing the negative ion  $AlO_2^-$ . The only other product is water.

Write a chemical equation for the reaction between aluminium oxide and aqueous sodium hydroxide.

..... [2]

(f) Gallium is in the same group as aluminium and forms similar compounds.

Predict the formulae of:

gallium(III) chloride .....

gallium(III) sulfate. ....

[2]

[Total: 15]

4 This question is about compounds of phosphorus.

- (a) Gaseous phosphorus(V) chloride decomposes into gaseous phosphorus(III) chloride and gaseous chlorine.

When the three gases are present in a closed container the system reaches equilibrium.



- (i) Complete the table using only the words *increases*, *decreases* or *no change*.

	effect on the rate of the forward reaction	effect on the equilibrium yield ( $\text{PCl}_3(\text{g})$ and $\text{Cl}_2(\text{g})$ )
increasing the temperature		increases
decreasing the pressure		
adding a catalyst		no change

[4]

- (ii) The table shows that when the temperature increases, the equilibrium yields of  $\text{PCl}_3(\text{g})$  and  $\text{Cl}_2(\text{g})$  increase.

State what conclusion can be made from this.

..... [1]

- (b) Complete the dot-and-cross diagram to show the electron arrangement in a molecule of phosphorus(III) chloride,  $\text{PCl}_3$ . Show outer shell electrons only.

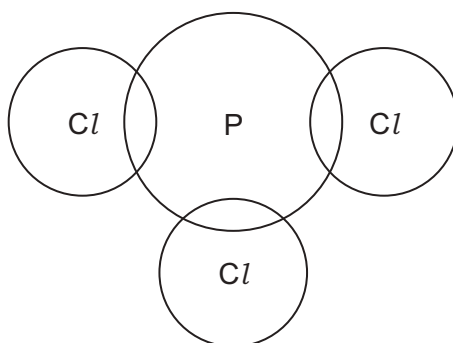

[2]

- (c) Phosphorus oxychloride has the formula  $\text{POCl}_3$ .

Phosphorus oxychloride is the only product of the reaction between phosphorus(V) chloride,  $\text{PCl}_5$ , and phosphorus(V) oxide,  $\text{P}_4\text{O}_{10}$ .

Write a chemical equation for the reaction between phosphorus(V) chloride and phosphorus(V) oxide.

..... [2]

- (d) Compound **X** has the following composition by mass.

H, 3.66%; P, 37.80%; O, 58.54%

Calculate the empirical formula of compound **X**.

empirical formula = ..... [2]

- (e) Compound **Y** has the empirical formula  $\text{H}_3\text{PO}_4$  and a relative molecular mass of 98.

Deduce the molecular formula of compound **Y**.

molecular formula = ..... [1]

[Total: 12]





5 This question is about sulfuric acid,  $\text{H}_2\text{SO}_4$ , and salts that can be made from sulfuric acid.

(a) Sulfuric acid is manufactured by the Contact process.

**stage 1** Molten sulfur burns in air to produce sulfur dioxide.

**stage 2** Sulfur dioxide reacts with oxygen to form sulfur trioxide,  $\text{SO}_3$ .

**stage 3** Sulfur trioxide reacts with concentrated sulfuric acid to form oleum,  $\text{H}_2\text{S}_2\text{O}_7$ .

**stage 4** Oleum is converted into sulfuric acid.

(i) The equation for the reaction in **stage 2** is shown.

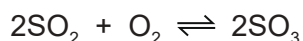

State the temperature and pressure used in **stage 2**.

Name the catalyst used in **stage 2**.

temperature ..... °C

pressure ..... atm

catalyst ..... [3]

(ii) Write the chemical equation for the reaction in **stage 3**.

..... [1]

(iii) Name the substance that reacts with oleum in **stage 4**.

..... [1]

(b) Name the black solid that is produced when concentrated sulfuric acid is added to sugar,  $\text{C}_{12}\text{H}_{22}\text{O}_{11}$ .

..... [1]

- (c) Dilute sulfuric acid and aqueous potassium hydroxide are used to make aqueous potassium sulfate.

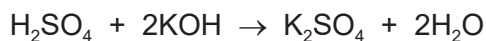

The method includes use of the following apparatus.

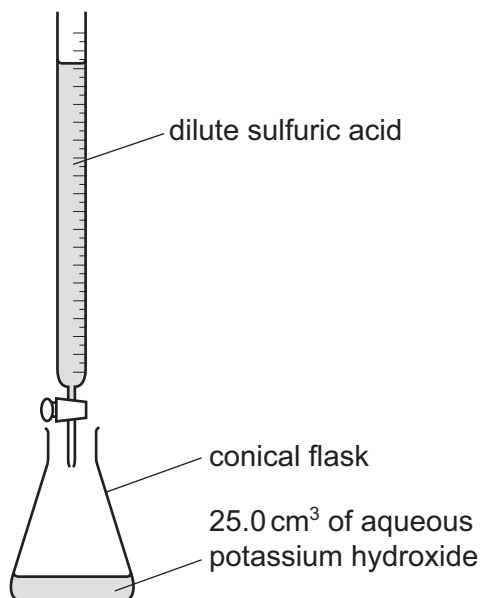

- (i) Calculate the volume of 0.0625 mol/dm<sup>3</sup> dilute sulfuric acid, H<sub>2</sub>SO<sub>4</sub>, that completely reacts with 25.0 cm<sup>3</sup> of 0.100 mol/dm<sup>3</sup> potassium hydroxide, KOH, to produce aqueous potassium sulfate.

Use the following steps.

- Calculate the number of moles of KOH in 25.0 cm<sup>3</sup> of 0.100 mol/dm<sup>3</sup> KOH.

= ..... mol

- Deduce the number of moles of H<sub>2</sub>SO<sub>4</sub> that react with KOH.

= ..... mol

- Calculate the volume of  $\text{H}_2\text{SO}_4$  required.

volume = .....  $\text{cm}^3$   
[3]

- (ii) The experiment is repeated using the same volume and concentration of potassium hydroxide and the same concentration of dilute sulfuric acid. In this second experiment, the product is aqueous potassium hydrogensulfate,  $\text{KHSO}_4$ .

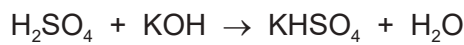

Use your answer to (c)(i) and the equation to deduce the volume of  $\text{H}_2\text{SO}_4$  required.

volume = .....  $\text{cm}^3$  [1]

- (d) Aqueous potassium hydrogensulfate,  $\text{KHSO}_4(\text{aq})$ , contains the ions  $\text{K}^+(\text{aq})$ ,  $\text{H}^+(\text{aq})$  and  $\text{SO}_4^{2-}(\text{aq})$ .

Describe the observations in the following tests.

- (i) A flame test is carried out on aqueous potassium hydrogensulfate.

..... [1]

- (ii) Solid copper(II) carbonate is added to aqueous potassium hydrogensulfate.

.....  
..... [2]

- (iii) An acidic solution containing aqueous barium ions,  $\text{Ba}^{2+}(\text{aq})$ , is added to aqueous potassium hydrogensulfate.

..... [1]

- (e) Write the ionic equation for the reaction in (d)(iii).

Include state symbols.

..... [3]

[Total: 17]

- 6 (a) Chloroethene ( $\text{CH}_2=\text{CHCl}$ ) can be manufactured from 1,2-dichloroethane ( $\text{CH}_2\text{ClCH}_2\text{Cl}$ ).

The equation can be represented as shown.

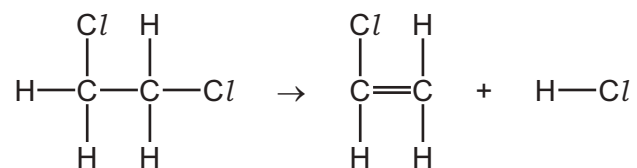

- (i) Some bond energies are given.

bond	bond energy in kJ/mol
C–C	350
C=C	610
C–Cl	340
C–H	410
H–Cl	430

Use the bond energies in the table to calculate the energy change, in kJ/mol, of the reaction.

Use the following steps.

- Calculate the energy needed to break bonds.

energy = ..... kJ

- Calculate the energy released when bonds form.

energy = ..... kJ

- Calculate the energy change of the reaction.

energy change of the reaction = ..... kJ/mol  
[3]

- (ii) Deduce whether the energy change for this reaction is exothermic or endothermic.

Give a reason for your answer.

.....  
..... [1]

- (b) Part of a synthetic polymer is shown.

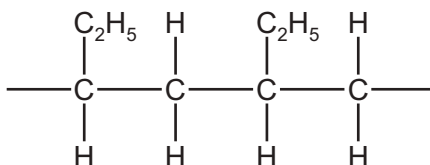

- (i) State the number of monomer units that are needed to make the part of the polymer shown.

..... [1]

- (ii) Name and draw the structure of the monomer used to make this polymer. Show all of the atoms and all of the bonds.

name .....

structure

[3]

- (iii) State the empirical formula of the polymer.

..... [1]

(c) Proteins are natural polymers.

Proteins are broken down into amino acids. The process is similar to how complex carbohydrates are broken down to give simple sugars.

(i) Name the type of reaction in which proteins are broken down into amino acids.

..... [1]

(ii) Name **two** types of substance that are used to break down proteins into amino acids.

1 .....

2 .....

[2]

(iii) Amino acids are colourless.

A sample containing a mixture of amino acids is separated. Each amino acid is detected and identified.

- Name the process used to separate the amino acids.

.....

- Name the type of substance used to detect the amino acids.

.....

- Give the symbol of the value used to determine the identity of each amino acid after separation and detection.

.....

[3]

(d) Proteins are natural polymers. Proteins contain amide linkages.

Synthetic polyamides also contain amide linkages.

(i) Name a synthetic polyamide.

..... [1]

(ii) Identify the **two** functional groups present in the monomers used to produce synthetic polyamides.

1 .....

2 .....

[2]

[Total: 18]

## The Periodic Table of Elements

		Group																																			
I	II	III	IV	V	VI	VII	VIII																														
1	2	3	4	5	6	7	8	9	10	11	12	13	14	15	16	17	18																				
Li lithium 7	Be beryllium 9	B boron 11	C carbon 12	Al aluminium 13	Si silicon 14	P phosphorus 15	S sulfur 16	Cl chlorine 17	Ar argon 18	K potassium 19	Ca calcium 20	Sc scandium 21	Ti titanium 22	V vanadium 23	Cr chromium 24	Mn manganese 25	Fe iron 26	Co cobalt 27	Ni nickel 28	Cu copper 29	Zn zinc 30	Ga gallium 31	Ge germanium 32	As arsenic 33	Se selenium 34	Br bromine 35	Kr krypton 36										
37	38	39	40	41	42	43	44	45	46	47	48	49	50	51	52	53	54	55	56	57-71 lanthanoids	72	73	74	75	76	77	78	79	80	81	82	83	84	85	86		
Rb rubidium 85	Sr strontium 88	Y yttrium 89	Zr zirconium 90	Nb niobium 91	Mo molybdenum 92	Tc technetium 93	Ru ruthenium 94	Rh rhodium 95	Pd palladium 96	Ag silver 97	Cd cadmium 98	In indium 99	Sn tin 100	Sb antimony 101	Te tellurium 102	I iodine 103	Xe xenon 104	Cs caesium 133	Ba barium 137	La lanthanum 139	Hf hafnium 178	Ta tantalum 181	W tungsten 184	Re rhenium 186	Os osmium 190	Ir iridium 192	Pt platinum 195	Au gold 197	Hg mercury 201	Tl thallium 204	Pb lead 207	Bi bismuth 209	Po polonium 210	At astatine 210	Rn radon 222		
87	88	89-103 actinoids	104	105	106	107	108	109	110	111	112	113	114	115	116	117	118	119	120	121	122	123	124	125	126	127	128	129	130	131	132	133	134	135	136	137	138
Fr francium —	Ra radium —	Ac actinium —	Rf rutherfordium —	Db dubnium —	Sg seaborgium —	Bh bohrium —	Hs hassium —	Mt meitnerium —	Ds darmstadtium —	Rg roentgenium —	Cn copernicium —	Fl flerovium —	Uu ununoctium —	Uub unubium —	Uut ununtrium —	Uuq ununquadium —	Uuq ununquadium —	Uup ununpentium —	Uuq ununquadium —	Uuh ununhexium —	Uuo ununoctium —	Uuq ununquadium —	Uuq ununquadium —	Uuq ununquadium —	Uuq ununquadium —	Uuq ununquadium —	Uuq ununquadium —	Uuq ununquadium —	Uuq ununquadium —	Uuq ununquadium —	Uuq ununquadium —	Uuq ununquadium —	Uuq ununquadium —	Uuq ununquadium —	Uuq ununquadium —		

Group

1  
H  
hydrogen  
1

Key

atomic number  
atomic symbol  
name  
relative atomic mass

lanthanoids	57 La lanthanum 139	58 Ce cerium 140	59 Pr praseodymium 141	60 Nd neodymium 144	61 Pm promethium —	62 Sm samarium 150	63 Eu europium 152	64 Gd gadolinium 157	65 Tb terbium 159	66 Dy dysprosium 163	67 Ho holmium 165	68 Er erbium 167	69 Tm thulium 169	70 Yb ytterbium 173	71 Lu lutetium 175
actinoids	89 Ac actinium —	90 Th thorium 232	91 Pa protactinium 231	92 U uranium 238	93 Np neptunium —	94 Pu plutonium —	95 Am americium —	96 Cm curium —	97 Bk berkelium —	98 Cf californium —	99 Es einsteinium —	100 Fm fermium —	101 Md mendelevium —	102 No nobelium —	103 Lr lawrencium —

The volume of one mole of any gas is 24 dm<sup>3</sup> at room temperature and pressure (r.t.p.).